

ARTSERIES

ACTIVE SPEAKER
ART 310A

RCF ART 310-A is an active, wide dispersion 2 way sound reinforcement speaker. It integrates a high power 350 watt amplifier, a complete electronic processor section and RCF low distortion, high power neodymium transducers. The system is unique in its class for output and vocal intelligibility. The new 10" neodymium woofer is the result of the latest refinement in year of RCF experience in compact 2 way speakers. Features a 2,5" voice coil, very high efficiency and controlled bass reproduction.

The compression driver uses a new 1.5" Mylar dome design and optimised geometry radial phase plug. This innovative design is powered from a high flux neodymium magnet offering a very open and natural midrange sound with extreme precision in high frequency reproduction.

A generous 2 step class H design is used to power the low frequencies and the compression driver amplifier is a warm and clear class AB design.

The input section presents a XLR input connector that is switchable from microphone to line levels. A master volume control and a useful XLR loop through link guarantee the best versatility.

The processor section includes active crossover, system equalisation, transducers phase alignment, limiter and protection functions. The system is visually monitored from 4 status LEDs. All the system is housed in a strong, very lightweight, polypropylene composite enclosure. The woofer is protected from a strong, powder coated, metal grille. The cabinet features 2 M10 threaded fly points, a 35 mm stand adaptor plus an ergonomic top handle for easy transportation.

Applications

ART 310-A is the reference speaker in the 10" size. Incredible amplifier power, high quality neodymium transducers, very compact size cabinet. From live sound, playback and monitoring to corporate events and presentations, ART 310-A is the ideal speaker in all the situations where the output of a PA and the size of a studio monitor is required. Superb deep bass punch, very linear and precise frequency response.

Features

- 350 watt Monolithic bi-amplification, 300 watt low frequency and 50 watt high frequency power
- 127 dB max SPL
- Wide dispersion, 90 x 70 low distortion, constant directivity horn
- 10" neodymium high power woofer
- 1" neodymium, high frequency driver
- Electronic equalization, phase alignment, limiter and protection
- Mic/Line XLR input, XLR signal output
- 1 comfortable top handle for easy transportation and positioning
- Two M10 fly points and built in pole mount adaptor

ACOUSTICAL SPECIFICATIONS

Frequency response:	50 - 20 KHz
Max SPL:	127 dB
Coverage angle:	90° x 70°
Directivity Factor; Q (Dl):	10.5 (10)
Compression driver:	neo 1"
Woofer:	neo 10"

INPUT SECTION

Input signal (Impedance):	bal/unbal
Input connector:	jack/xlr
Output signal connector:	xlr
Input sensitivity:	0 dBu
Mic. input sensitivity:	-40 dBu

PROCESSOR SECTION

Crossover frequencies:	1800 Hz
Protections:	DC / short cir.
Limiter:	fast limiter
Master volume:	yes
Music / Voice eq:	yes
Remote control option:	yes

AMPLIFIER

Nominal power:	350 Watt
High frequencies:	ab / 50 Watt
Low frequencies:	H / 300 Watt
Cooling:	Convection

PHYSICAL

Cabinet:	Composite PP
Dimensions (HxWxD):	21.14" x 13.27" x 12.4" (537x337x315 mm)
Weight:	27.34 lbs. (12,4 kg)
Hardware:	2 M10 flying points
Handles:	1 top
Pole Mount / Cap:	yes
Colour:	Anthracyte gray

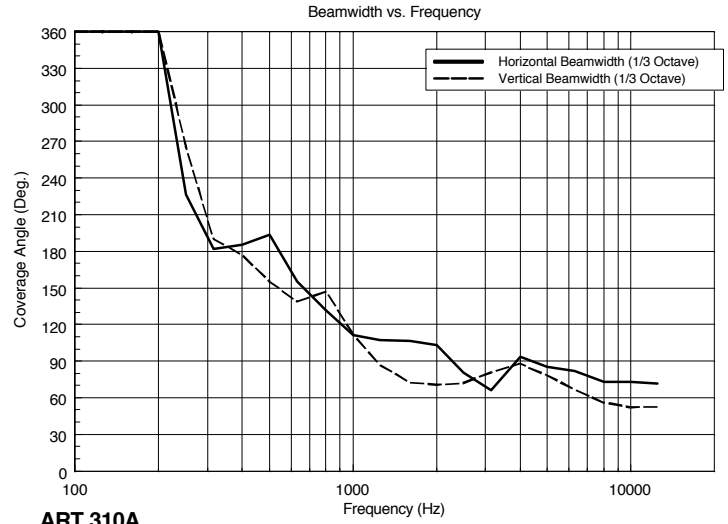
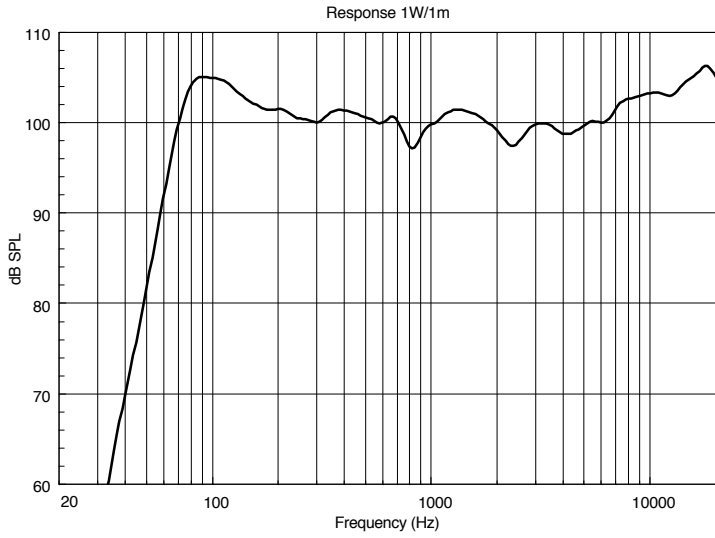

ART 310A

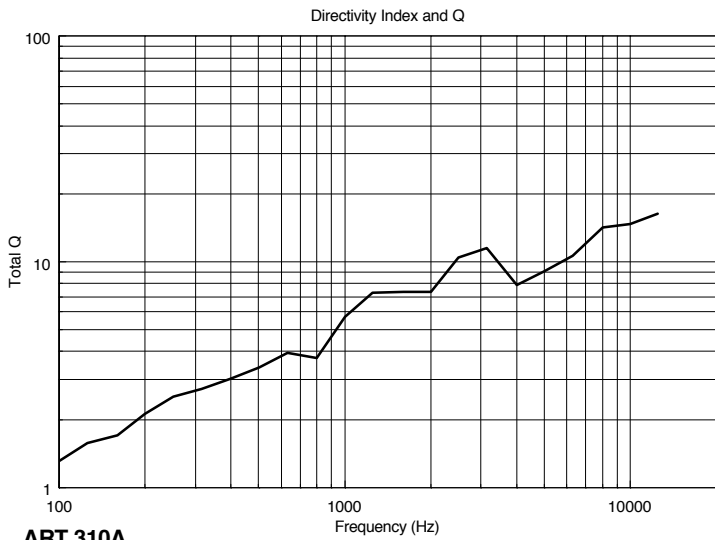

ART 310A

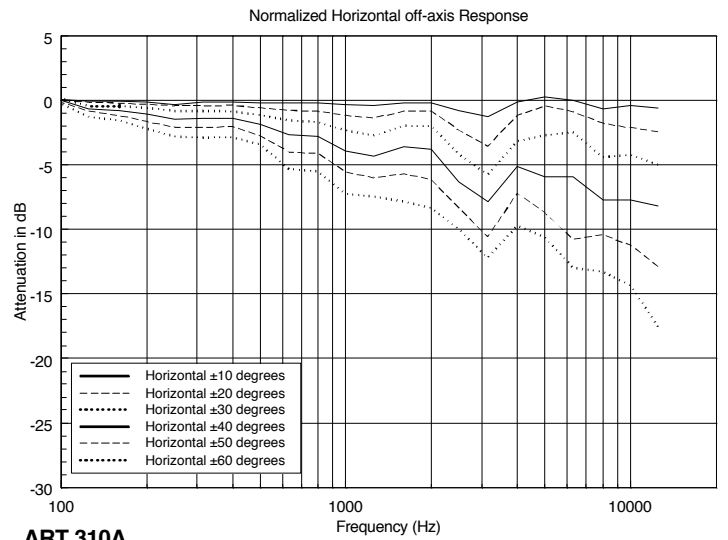

ART 310A

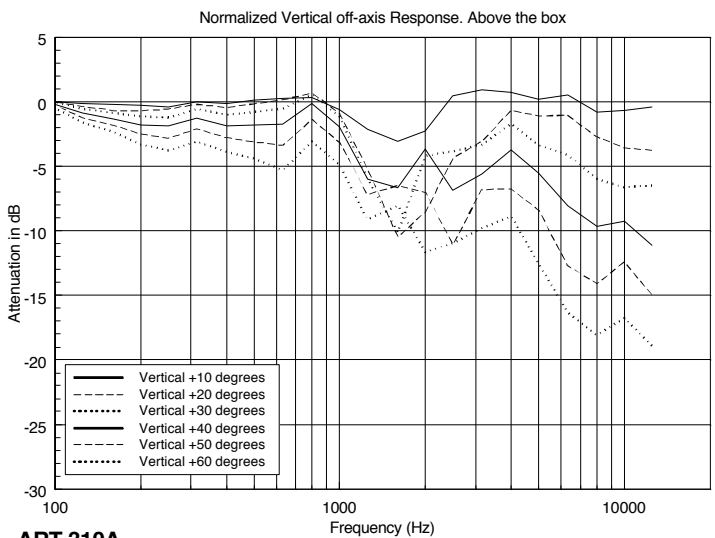

ART 310A

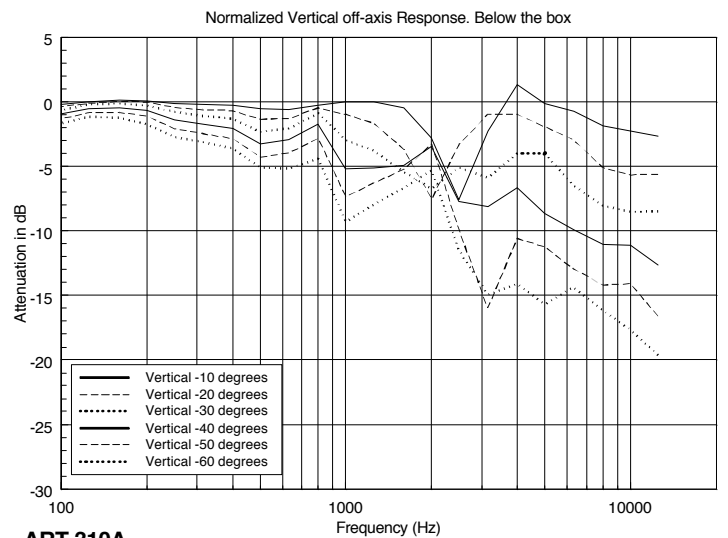

ART 310A

Horizontal 1/3 Polar Plot

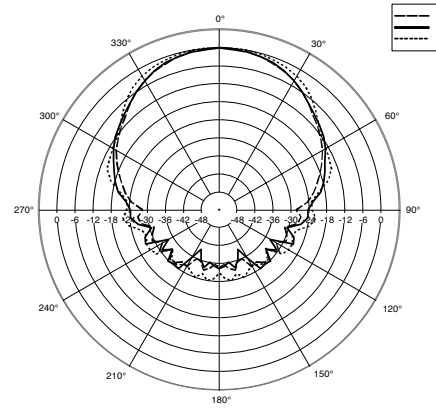
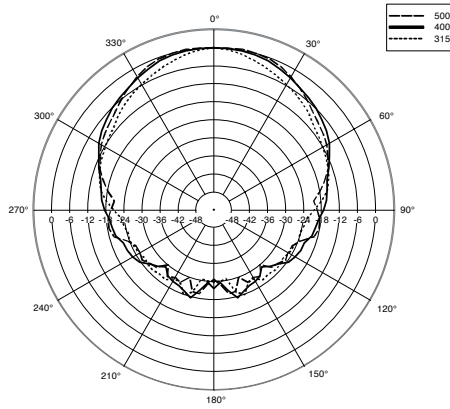
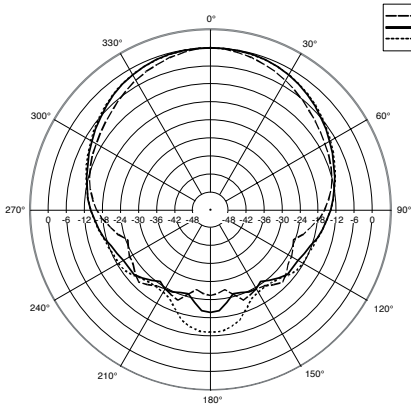
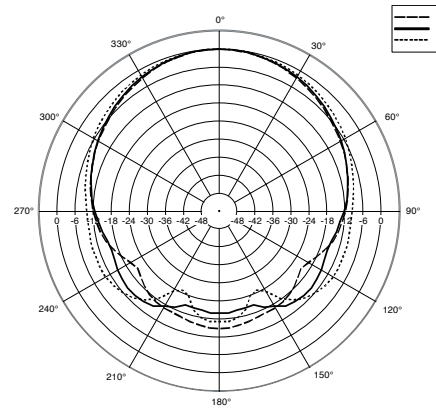
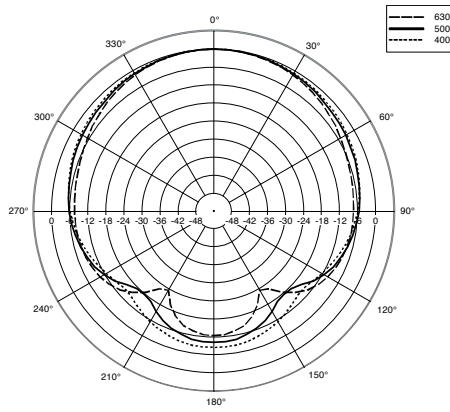
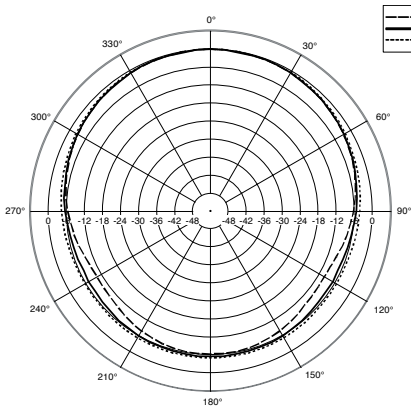

Vertical 1/3 Polar Plot

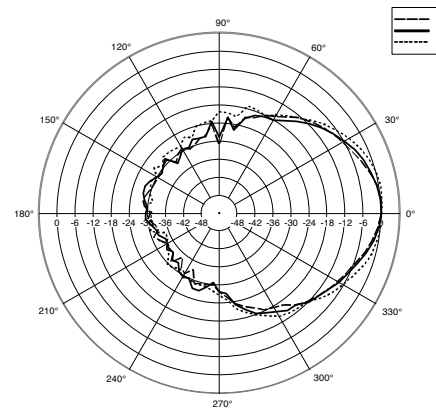
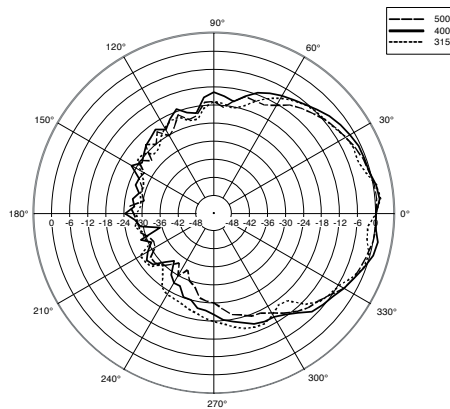
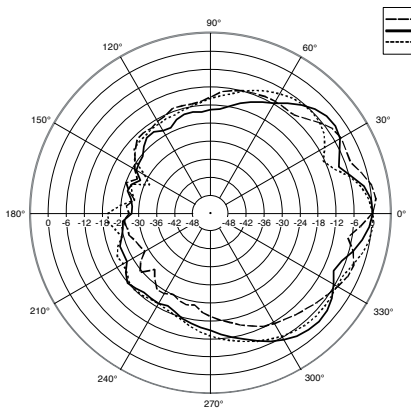
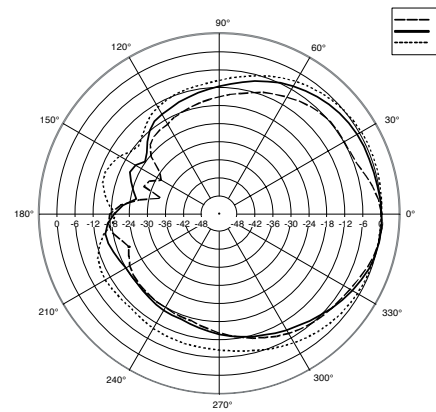
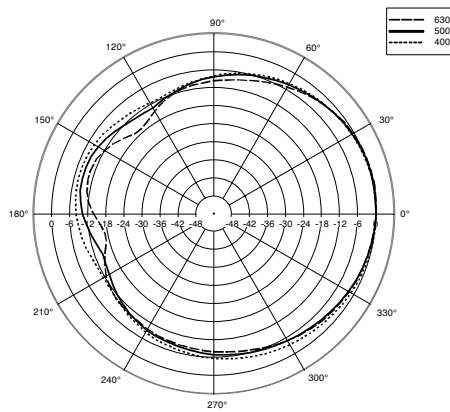
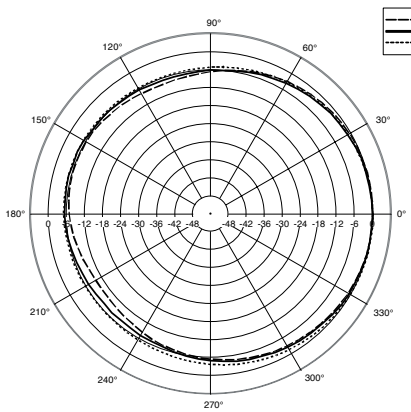

CSI PRODUCT SPECIFICATIONS FOR DESIGNERS, SPECIFIERS, AND CONSULTANTS (ALSO KNOWN AS “A&E SPECIFICATIONS”) The following are “Part 2 Products” CSI-type specifications. It is assumed that “Part 1 General – Administrative and Procedures” and “Part 3 Execution – Installation and Maintenance” are part of an overall audio system or project specification.
PART 2 PRODUCTS

2.01 Approved Manufacturer/Product

A. RCF, Via Raffaello 13, 42010 Mancasale, Reggio Emilia, Italy.

B. Model number: ART 310A

2.02 Design

Configuration	Compact 2 way speaker
LF Sub-section	10" woofer, 2,5" voice coil
HF Sub-section	1" neodymium

2.03 Acoustical Proprieties

Nominal dispersion angle:	Horizontal: 90° - Vertical: 70°
Axial frequency range:	50Hz-20kHz

2.04 Physical Properties

Cabinet:	Composite PP
Rigging inserts:	2 M10 fly points and built in pole mount adaptor
Color:	Anthracyte gray
Grille:	Custom perforated steel grille with open-cell poly fiber backing
Input Connectors:	jack/xlr
Dimensions (H x W x D):	21.14" x 13.27" x 12.4" (537x337x315 mm)
Weight:	27.34 lbs. (12,4 kg)

2.05 Accessories

AC S140	Alluminium speaker floor stand with folding base end telescopic rod, tube Ø 35 mm
---------	---

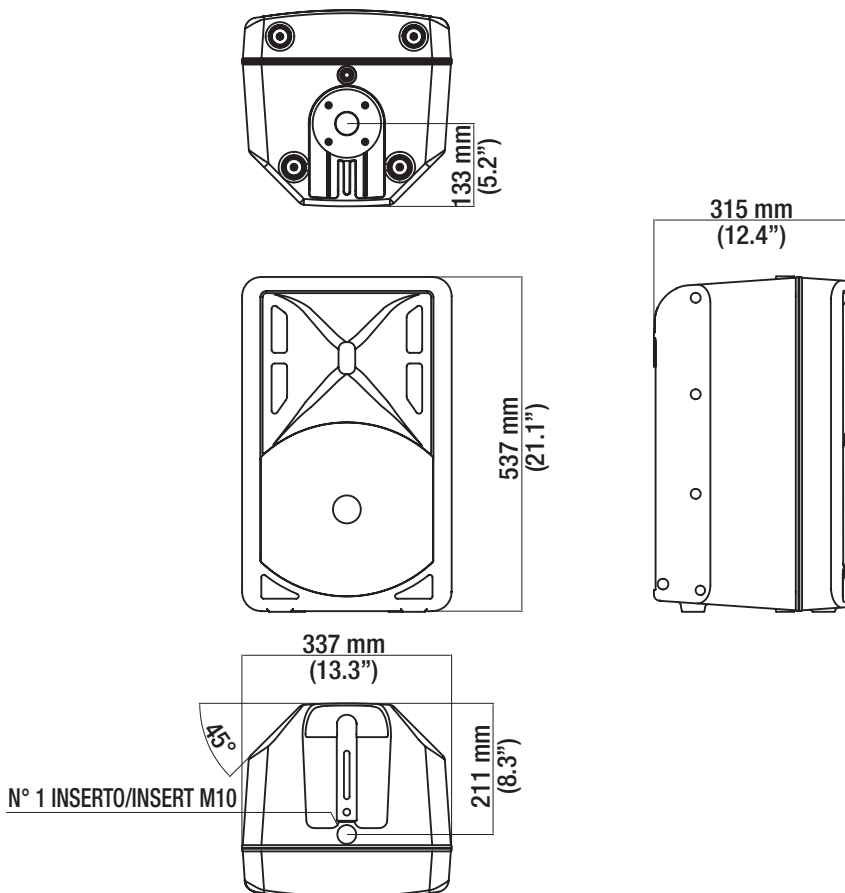

RCF SpA Italy:
tel. +39 0522 274 411
fax +39 0522 232 428
www.rcfaudio.com
e-mail: info@rcf.it

RCF UK Sales Office:
tel. +44 7005 402181
e-mail: info@rcfaudio.co.uk

RCF France Sales Office:
tel. +33 6 07501800
e-mail: rcfrance@aol.com

RCF Germany Sales Office:
tel. +49 2203 925370
e-mail: germany@rcf.it

RCF USA Sales Office:
tel. +1 (603) 926 4604
e-mail: rcf-usa@comcast.net